



# Fishing

## Merit Badge Workbook

This workbook can help you but you still need to read the merit badge pamphlet (book). No one can add or subtract from the Boy Scout Requirements #33215. Merit Badge Workbooks and much more are below: [Online Resources](#).

Workbook developer: [craig@craiglincoln.com](mailto:craig@craiglincoln.com). Requirements revised: 2002, Workbook updated: August 2008.

Scout's Name: \_\_\_\_\_ Unit: \_\_\_\_\_

Counselor's Name: \_\_\_\_\_ Counselor's Ph #: \_\_\_\_\_

1) Explain to your counselor the injuries that could occur while fishing and the proper treatment, including

cuts, scratches, \_\_\_\_\_

puncture wounds, \_\_\_\_\_

insect bites, \_\_\_\_\_

hypothermia, \_\_\_\_\_

dehydration, \_\_\_\_\_

and heat reactions. \_\_\_\_\_

Explain how to remove a hook that has lodged in your arm. \_\_\_\_\_

Name and explain five safety practices you should always follow while fishing.

\_\_\_\_\_  
\_\_\_\_\_  
\_\_\_\_\_  
\_\_\_\_\_  
\_\_\_\_\_

2) Learn and explain the differences between two types of fishing outfits. Type 1: \_\_\_\_\_

Type 2: \_\_\_\_\_ Differences: \_\_\_\_\_

Point out and identify the parts of several types of rods and reels. Explain how and when each would be used. Review with your counselor how to care for this equipment.

Sample Spin Casting Reel



How used: \_\_\_\_\_

When used: \_\_\_\_\_

Care: \_\_\_\_\_

Sample Saltwater Reel

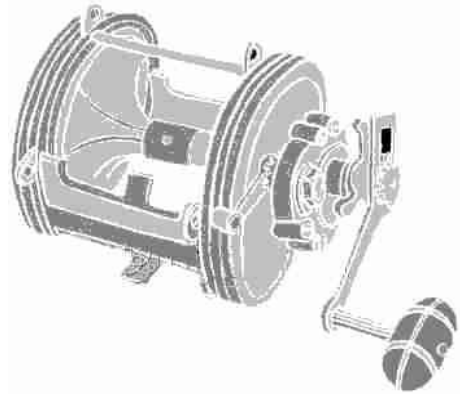

\_\_\_\_\_

\_\_\_\_\_

\_\_\_\_\_

Sample Spinning Rod & Reel

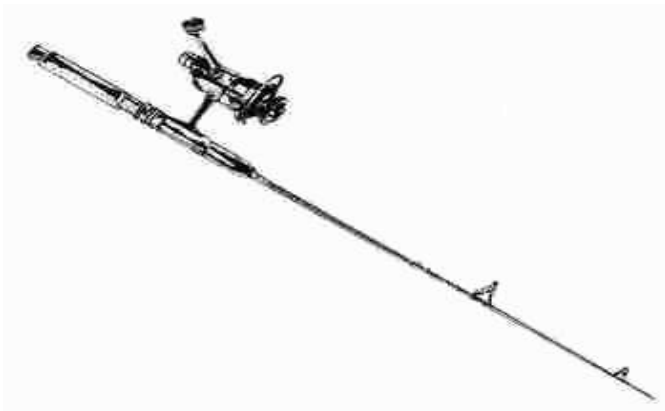

How used: \_\_\_\_\_

When used: \_\_\_\_\_

Care: \_\_\_\_\_

Sample Fly Fishing Rod & Reel



\_\_\_\_\_

\_\_\_\_\_

\_\_\_\_\_

Sample Fishing Rods



Care: \_\_\_\_\_

3) Demonstrate the proper use of two different types of fishing equipment. \_\_\_\_\_

\_\_\_\_\_

4) *Demonstrate* how to tie the following knots: clinch, palomar, turle, blood loop (barrel knot), and the surgeon's loop. Explain how each knot is used and when to use it.

clinch, \_\_\_\_\_

palomar, \_\_\_\_\_

turle, \_\_\_\_\_

blood loop (barrel knot), \_\_\_\_\_

and the surgeon's loop. \_\_\_\_\_

5) Name and Identify five Artificial Lures and explain how to fish with them:

\_\_\_\_\_

\_\_\_\_\_

\_\_\_\_\_

\_\_\_\_\_

\_\_\_\_\_

Name and Identify five Natural Baits and explain how to fish with them:

\_\_\_\_\_

\_\_\_\_\_

\_\_\_\_\_

\_\_\_\_\_

\_\_\_\_\_

Explain why baitfish are not to be released. \_\_\_\_\_

\_\_\_\_\_

\_\_\_\_\_

6) Explain the importance of practicing Leave No Trace and how it positively affects fishing resources. \_\_\_\_\_

\_\_\_\_\_

\_\_\_\_\_

\_\_\_\_\_

\_\_\_\_\_

\_\_\_\_\_

\_\_\_\_\_

7) Give the regulations affecting game fishing where you live. Explain why they were adopted and what you accomplish by following these regulations.

\_\_\_\_\_

\_\_\_\_\_

\_\_\_\_\_

---



---



---



---



---

8) Explain what good outdoor sportsmanlike behavior is and how it relates to fishermen. \_\_\_\_\_

---



---



---

Tell how the Outdoor Code of the Boy Scouts of America relates to a fishing sports enthusiast, including the aspects of littering, trespassing, courteous behavior, and obeying fishing regulations. \_\_\_\_\_

---



---



---

9) Catch two different kinds of fish and identify them. \_\_\_\_\_

Release at least one of them unharmed. Clean and cook another fish. \_\_\_\_\_

---

**Online Resources** (Use any Internet resource with caution and only with your parent's or guardian's permission.)

**Boy Scouts of America:** ▶ [scouting.org](http://scouting.org) ▶ [Guide to Safe Scouting](#) ▶ [Age-Appropriate Guidelines](#) ▶ [Safe Swim Defense](#)  
▶ [Scout](#) ▶ [Tenderfoot](#) ▶ [Second Class](#) ▶ [First Class](#) ▶ [Rank Videos](#) ▶ [Safety Afloat](#)

**Boy Scout Merit Badge Workbooks:** [usscouts.org](http://usscouts.org) -or- [meritbadge.org](http://meritbadge.org) **Merit Badge Books:** [www.scoutstuff.org](http://www.scoutstuff.org)  
▶ [Leave No Trace](#) ▶ [Outdoor Code](#) ▶ [Wilderness Use Policy](#) ▶ [Youth Protection Training](#)

[ExpertVillage First Aid Videos](#) ▶ [Make a First Aid Kit](#) ▶ [Basics](#) ▶ [Basics2](#) ▶ [CPR Basics](#) ▶ [Venomous Snake Bite](#)  
[ExpertVillage Fishing Videos](#) ▶ [Basics for Kids](#) ▶ [Advanced Fishing](#) ▶ [How to Fillet a Fish](#)

American Fisheries Society: <http://www.fisheries.org>

American Zoo and Aquarium Association: <http://www.aza.org>

American Sportfishing Assn.: <http://www.asafishing.org>

Future Fisherman Foundation: <http://www.futurefisherman.org>

Izaak Walton League of America: <http://www.iwla.org>

National Oceanic and Atmospheric Administration Fisheries: <http://www.nmfs.noaa.gov>

Nat. Fish and Wildlife Foundation: <http://www.nfwf.org>

National Park Service: <http://nps.gov>

Trout Unlimited: <http://www.tu.org>

U.S. Fish and Wildlife Service: <http://www.fws.gov>

## Wilderness Use Policy of the Boy Scouts of America

All privately or publicly owned backcountry land and designated wildernesses are included in the term “wilderness areas” in this policy. The Outdoor Code of the Boy Scouts of America and the principles of Leave No Trace apply to outdoor behavior generally, but for treks into wilderness areas, minimum-impact camping methods must be used. Within the outdoor program of the Boy Scouts of America, there are many different camping-skill levels. Camping practices that are appropriate for day outings, long-term Scout camp, or short-term unit camping might not apply to wilderness areas. Wherever they go, Scouts need to adopt attitudes and patterns of behavior that respect the rights of others, including future generations, to enjoy the outdoors.

- In wilderness areas, it is crucial to minimize human impact, particularly on fragile ecosystems such as mountains, lakes and streams, deserts, and seashores. Because our impact varies from one season of the year to the next, it becomes important for us to adjust to these changing conditions to avoid damaging the environment.
- The Boy Scouts of America emphasizes these practices for all troops, teams, and crews planning to use wilderness areas:
- Contact the landowner or land-managing agency (USDA Forest Service, National Park Service, Bureau of Land Management, U.S. Fish and Wildlife Service, U.S. Army Corps of Engineers, state and private agencies, etc.) well before an outing to learn the regulations for that area, including group size limits, to obtain required permits and current maps, and to discuss ways Scouts can fulfill the expectations of property owners or land managers.
- Obtain a tour permit (available through local council service centers), meet all of its conditions, and carry it during the trip.
- Review the appropriate BSA safety literature relating to planned activities. (See Safe Swim Defense, Safety Afloat, Climb On Safely, and Trek Safely.) Also see the Guide to Safe Scouting on the BSA Web site at <http://www.scouting.org/pubs/gss/toc.html> for more information on current BSA policies and procedures for ensuring safe activities, as well as the Fieldbook Web site at <http://www.bsafieldbook.org>.
- Match the ruggedness of high-adventure experiences to the skills, physical ability, and maturity of those taking part. Save rugged treks for older unit members who are more proficient and experienced in outdoor skills.
- Conduct pretrip training for your group that stresses proper wilderness behavior, rules, and skills for all of the conditions that may be encountered, including lightning, missing person, wildfire, high winds, flooding, and emergency medical situations.
- Participate in training in how to apply the principles of Leave No Trace, and be proficient and experienced in the leadership and skills required for treks into wilderness areas.
- Adhere to the principles of Leave No Trace.

### The Principles of Leave No Trace

1. Plan Ahead and Prepare
2. Travel and Camp on Durable Surfaces
3. Dispose of Waste Properly (Pack It In, Pack It Out)
4. Leave What You Find
5. Minimize Campfire Impacts
6. Respect Wildlife
7. Be Considerate of Other Visitors

### Outdoor Code

As an American, I will do my best to—

**Be clean in my outdoor manners.** I will treat the outdoors as a heritage. I will take care of it

for myself and others. I will keep my trash and garbage out of lakes, streams, fields, woods, and roadways.

**Be careful with fire.** I will prevent wildfire. I will build my fires only when and where they are appropriate. When I have finished using a fire, I will make sure it is cold out. I will leave a clean fire ring, or remove all evidence of my fire.

**Be considerate in the outdoors.** I will treat public and private property with respect. I will follow the principles of Leave No Trace for all outdoor activities.

**Be conservation-minded.** I will learn about and practice good conservation of soil, waters, forests, minerals, grasslands, wildlife, and energy. I will urge others to do the same.